

# etekcity™

## Smart Nutrition Scale

**Model:** ESN00 Series

## User Manual

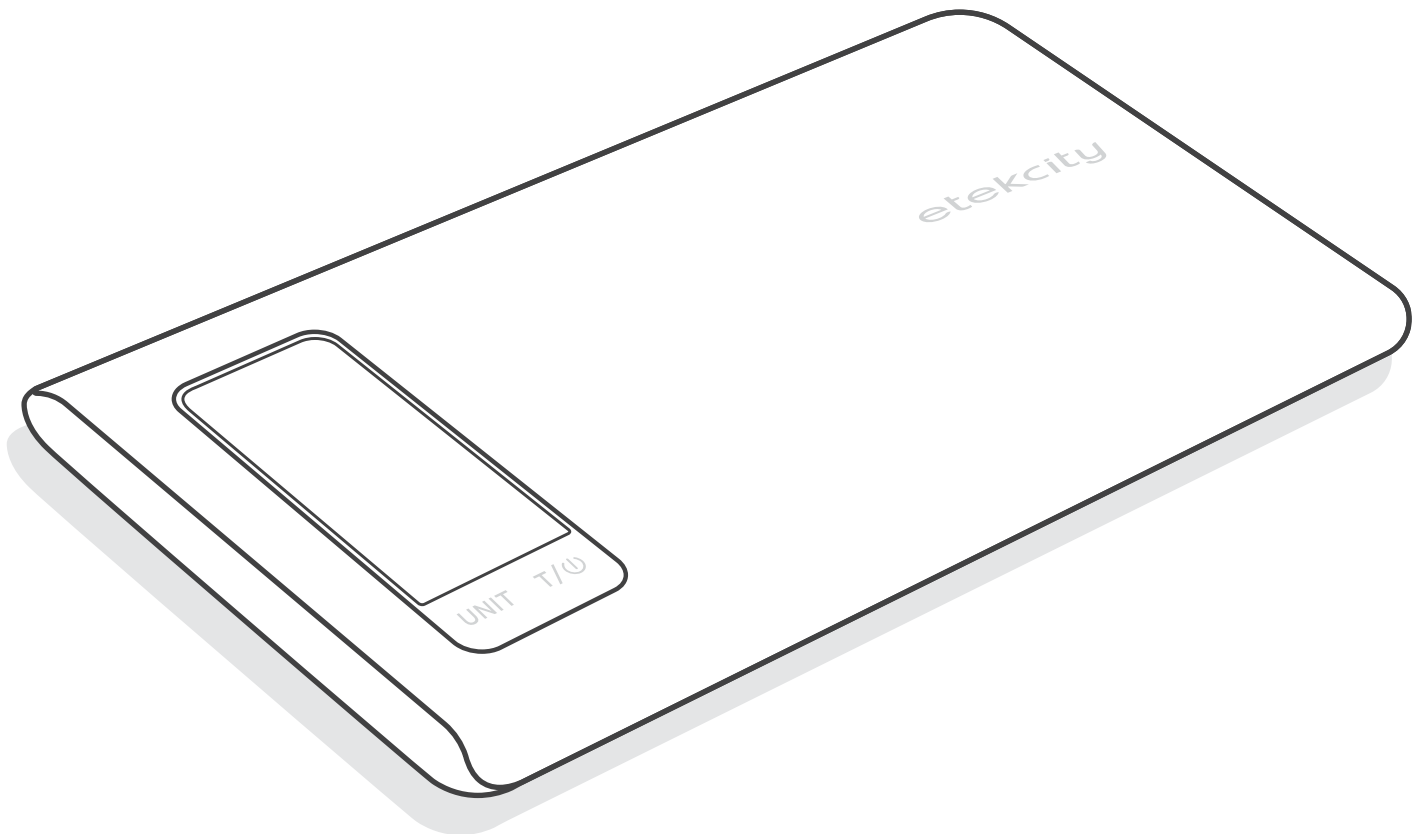

### Questions or Concerns?

Mon–Fri, 9:00 am–5:00 pm PST/PDT  
support@etekcity.com • 1-855-686-3835

## Table of Contents

Package Contents	3
Specifications	3
Safety Information	4
Function Diagram	6
Digital Display	7
Setup	8
VeSync App Setup	9
Scale Operation	10
Maintenance	14
Troubleshooting	15
Warranty Information	17
Customer Support	22

## Package Contents

1 x Smart Nutrition Scale  
3 x 1.5V AAA Batteries (Pre-Installed)  
1 x Quick Start Guide

## Specifications

<b>Weight Capacity</b>	176.4 oz / 11 lb / 5000 g / 5000 mL
<b>Units</b>	oz / lb:oz / g / mL
<b>Increments</b>	0.1 oz / 1 g / 1 mL
<b>Backlight Auto-Off</b>	30–120 seconds (adjustable in the VeSync app)
<b>Scale Auto-Off</b>	120 seconds
<b>Dimensions</b>	9.2 x 6.3 x 0.6 in / 235 x 160 x 17 mm
<b>Battery</b>	3 x 1.5V AAA Batteries

**Note:** To access additional smart nutrition scale functions, download the free VeSync app (see page 9).



# READ AND SAVE THESE INSTRUCTIONS

## Safety Information

**To avoid damage to this scale, please read and follow all instructions and safety guidelines in this manual.**

### Scale

- **Do not** exceed the 11 lb / 5 kg weight capacity, as doing so may damage the scale. An overload indicator will appear on the LCD display if the limit is exceeded.
- Smart scales are not waterproof. **Do not** immerse the scale in water or any liquid. If liquid is spilled on the digital display or buttons, immediately wipe the scale clean with a soft cloth to avoid internal damage.
- Handle with care. This scale is not intended for commercial or heavy-duty use.
- Keep the scale in a cool, dry place. Avoid exposing to damp environments or extreme temperatures.
- Household use **only**.



## Batteries

- **Do not** mix new and old batteries.
- If the low battery indicator ("**Lo**") appears on the display, replace the batteries.
- If the scale is not in use for an extended period of time, remove the batteries to conserve battery life and extend the lifetime of the scale.



## Function Diagram

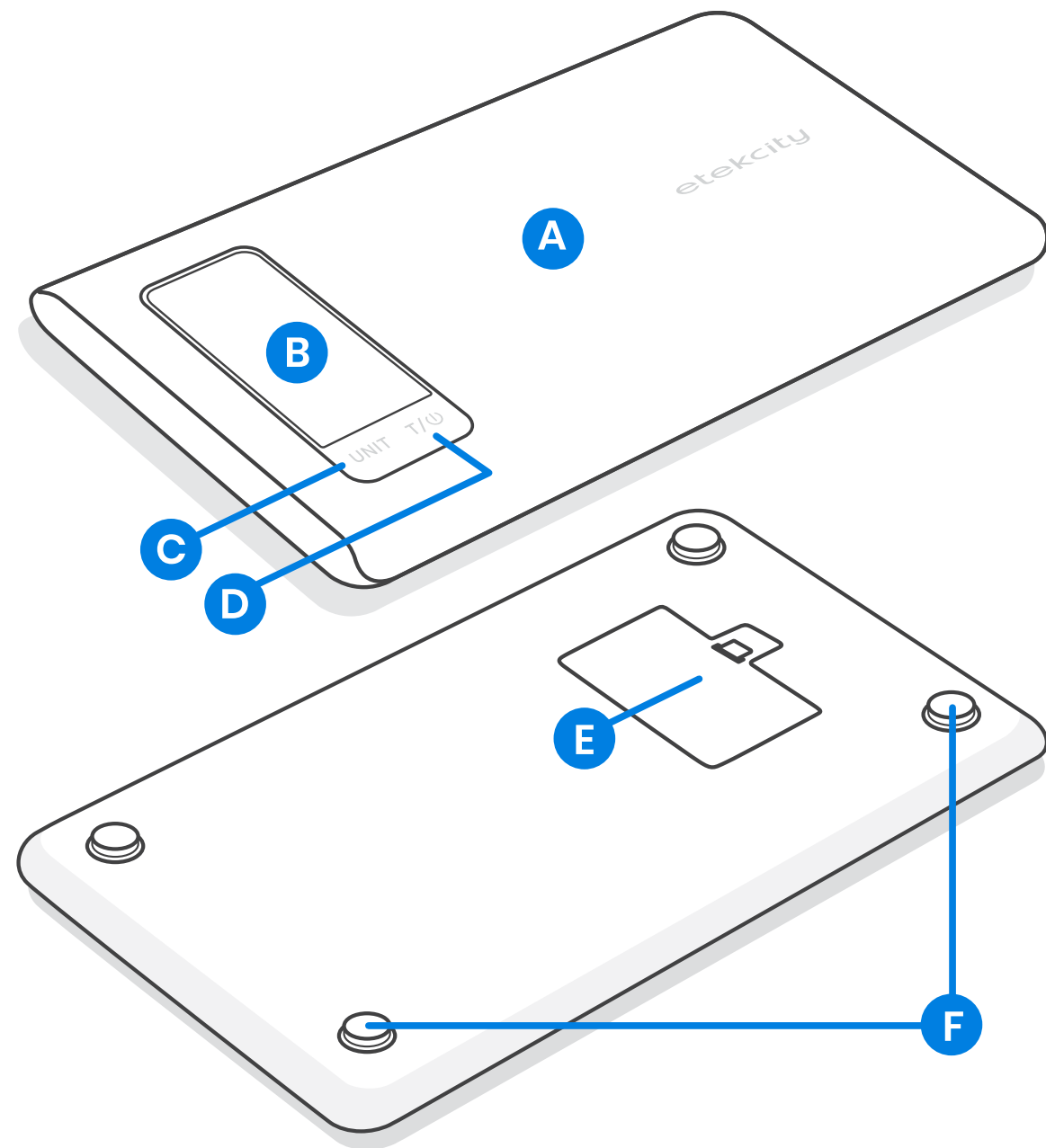

- A.** Weighing Platform
- B.** Digital Display
- C.** Unit Switching Button
- D.** Power/Tare Button
- E.** Battery Compartment
- F.** Anti-Skid Pads

## Digital Display

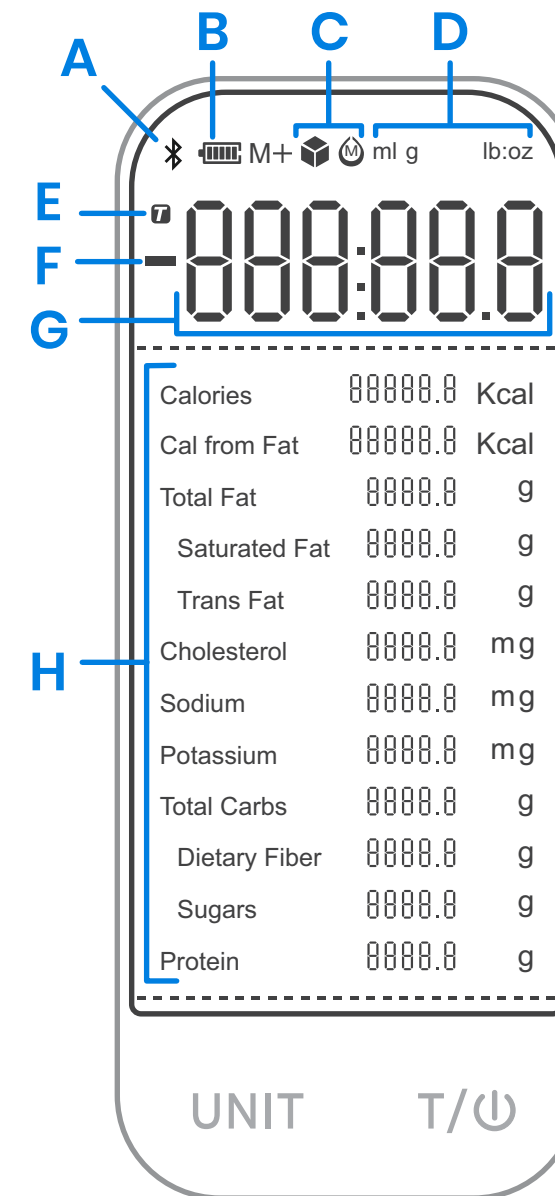

- A.** Bluetooth® Icon
- B.** Battery Life Indicator
- C.** Weighing Mode
- D.** Measurement Unit
- E.** Tare Mode
- F.** Negative Weight Value
- G.** Weight Value
- H.** Nutritional Information

## Setup

1. Open the battery compartment on the underside of the scale.
2. If necessary, insert the included AAA batteries, making sure they are under the correct polarity as marked in the battery compartment. [\[Figure 1.1\]](#)
3. Replace the battery cover.
4. Press **T/⏻** to turn on the scale.

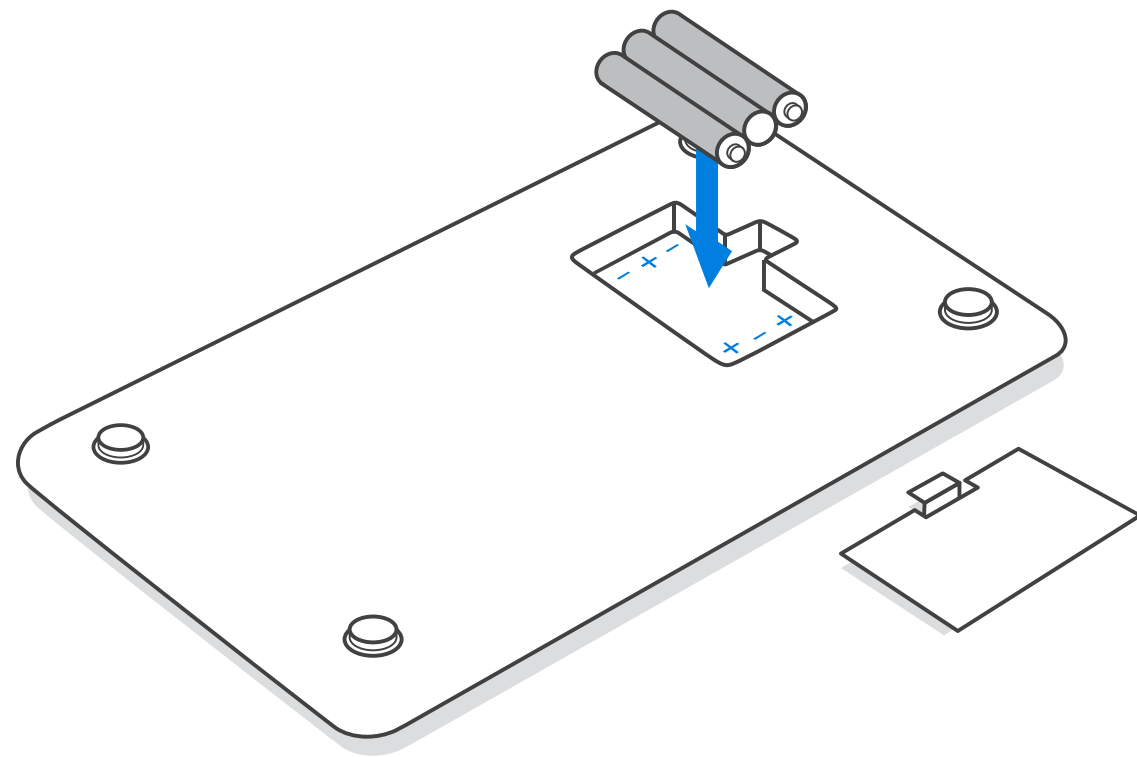

Figure 1.1

## VeSync App Setup

**Note:** Due to app updates and improvements, the VeSync app may be slightly different than shown in the manual. In case of any differences, follow the in-app instructions.



1. To download the VeSync app, scan the QR code or search “VeSync” in the Apple App Store® or Google Play Store.

**Note:**

- This scale uses the VeSync app, not the VeSyncFit app.
- For Android™ users, choose “Allow” (when prompted) to use VeSync.

2. Open the VeSync app. If you already have an account, tap **Log In**. To create a new account, tap **Sign Up**.

**Note:** You must create your own VeSync account to use third-party services and products. These will not work with a guest account. With a VeSync account, you can also allow your family or friends to use your nutrition scale. Even if you get a new phone, your nutrition records will still be available on your account.

3. Tap **+** in the VeSync app and select your smart nutrition scale.
4. Follow the in-app instructions to connect your phone to your smart nutrition scale.

**Note:** You can change the name and icon at any time in the smart nutrition scale settings.

## Scale Operation

### Tips

- For accurate results, always place the scale on a hard, dry, flat surface, and keep the scale away from dirt, dust, vibration, wind, air currents, and electromagnetic interference.
- When you turn on the scale, choose units, or use the Tare function, always wait for the scale to read "0" before attempting measurement.
- To see nutrition information besides weight or volume, or to record food in the app, you must connect the scale to the VeSync app (see page 9).

## Measurement

1. Press **T/⏻** to turn on the scale. Press **UNIT** to select your desired measuring unit, which will show at the top of the display. **[Figure 2.1]** You can also change the measurement unit in the VeSync app.
  - a. **Weight:** Choose between ounces ("oz"), both pounds and ounces ("lb:oz"), or grams ("g").
  - b. **Volume:** Scale measures in milliliters ("ml"). Select water (droplet image) or milk ("m" droplet image) options.

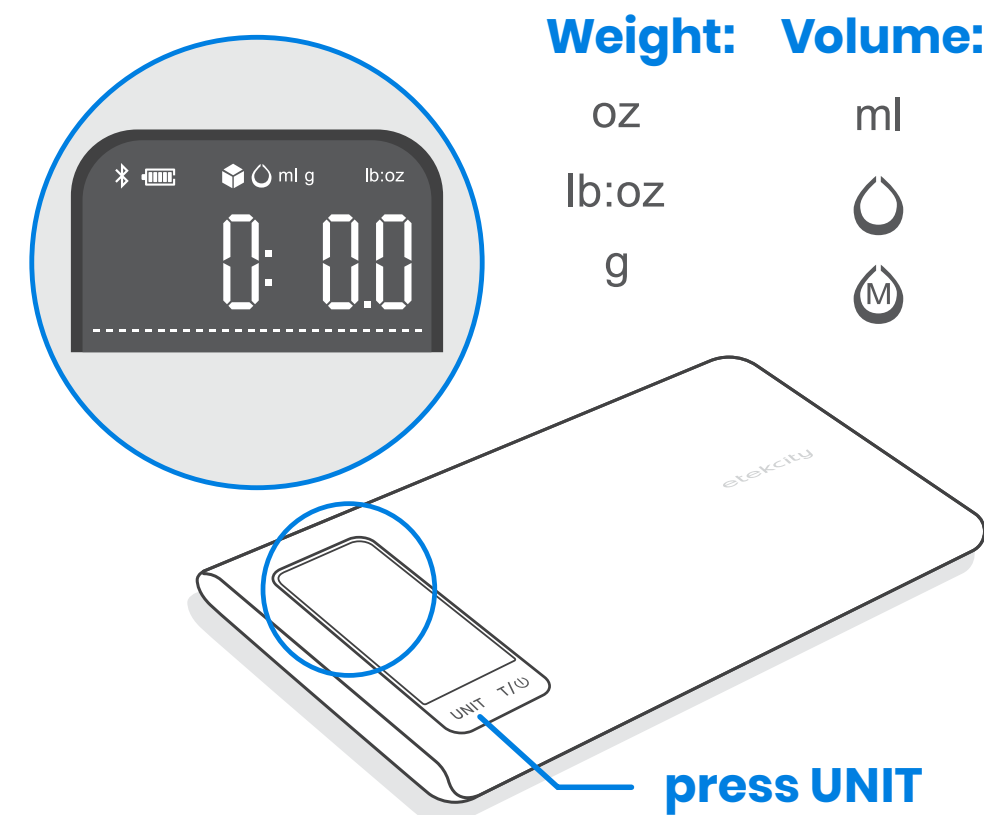
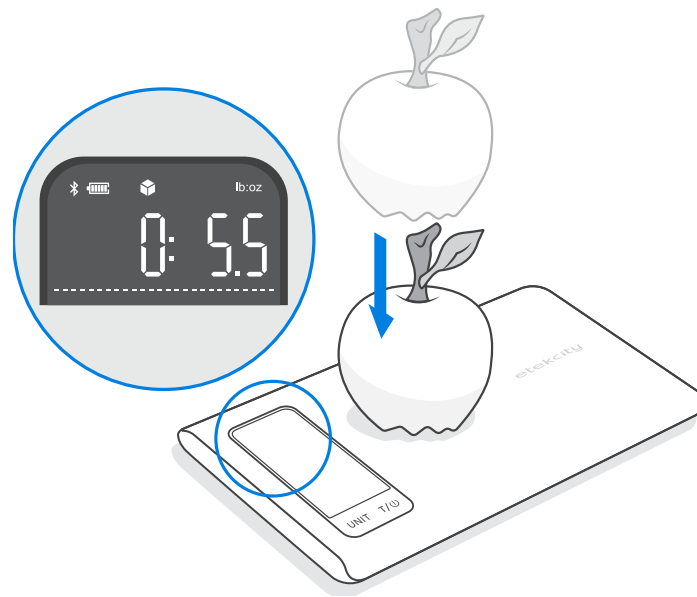

**Figure 2.1**

2. **Optional:** If you're using a container to hold the items or liquid you're measuring, first place the empty container on the scale. Press **T/⏻** to zero out (tare) the container's weight (see **Tare Function**, page 13).
3. Gently place your item on the scale. The display will show the weight or volume. [\[Figure 2.2\]](#) If your smart scale is connected to the VeSync app, the weight will be synchronized with the VeSync app.
4. Press and hold **T/⏻** for 3 seconds to turn off the scale.

**Note:**

- To reset the scale, remove all weight from the platform and press **T/⏻**.
- To conserve battery power, the scale will automatically turn off after 2 minutes of inactivity. The display backlight will automatically turn off after 30 seconds of inactivity. You can change this in the VeSync app.



[Figure 2.2](#)

## Tare Function

Whenever you measure liquid or items inside a container, you can use the Tare function to remove the container's weight from the final measurement.

1. Place an empty container on the scale. The display will show the container's weight. [\[Figure 2.3\]](#)
2. Press **T/⏻**. The display will show "0" again. [\[Figure 2.4\]](#)
3. Place liquid or items in the container. The scale will now measure the liquid or items, without including the weight of the container. [\[Figure 2.5\]](#)
4. When you're done, reset the scale by removing all weight and pressing **T/⏻**.



[Figure 2.3](#)

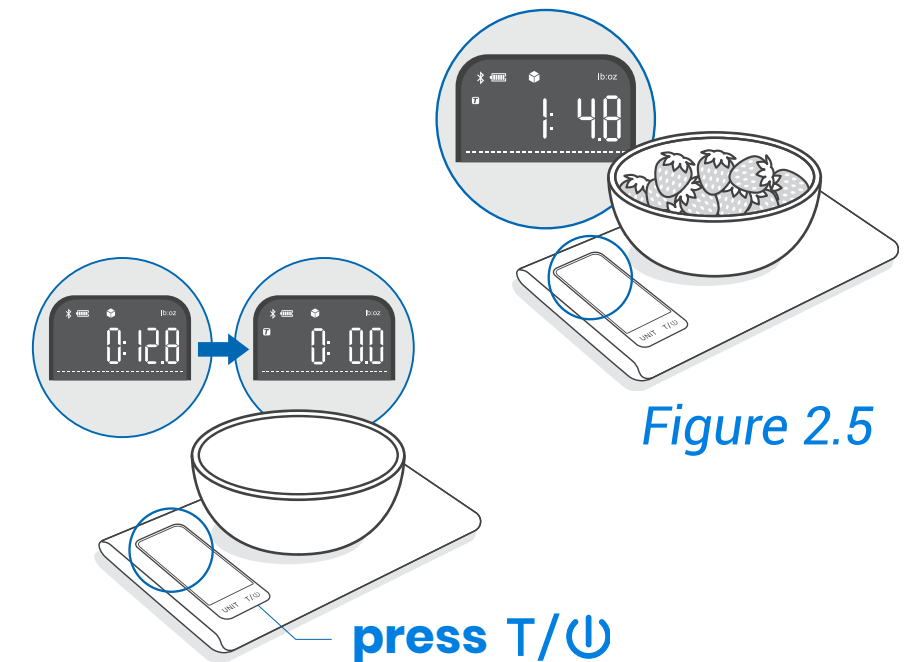

[Figure 2.4](#)

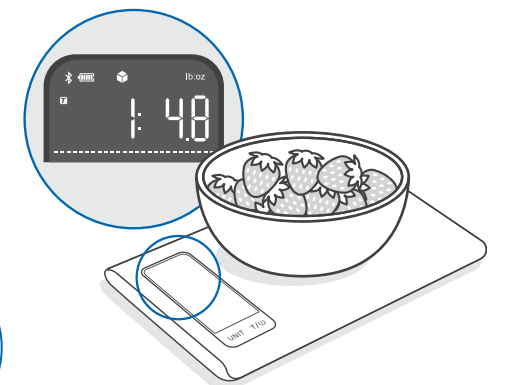

[Figure 2.5](#)



## Maintenance

- Use a slightly damp cloth to clean the surface of the scale, followed by a dry, soft cloth to wipe away the remaining moisture.
- You can use a dry, soft cloth to wipe dust off the scale.
- **Do not** wash the scale or immerse it in water or any other liquid.

## Troubleshooting

Problem	Possible Solution
<b>LCD display is dim.</b>	Scale may be on standby. Place an item on the scale for measurement, or turn off the scale by pressing and holding <b>T/⏻</b> for 3 seconds.
	Replace the batteries.
<b>LCD display shows "Lo".</b>	Battery is low. Replace the batteries.
<b>Scale does not turn on.</b>	Make sure the plastic strip is removed from the battery compartment on the underside of the scale.
	Replace the batteries.
	Insert batteries under the correct polarity as marked in the battery compartment.
<b>Scale cannot connect to the VeSync app.</b>	Make sure your mobile device is within 30 ft / 10 m of the scale.
	Some Bluetooth devices can only exchange data with 1 other Bluetooth device at a time. Make sure the scale is not currently connected to any other phone or app.
<b>Display shows "Err".</b>	Weight exceeds 176.4 oz / 11 lb / 5000 g / 5000 mL. Promptly remove item from scale to protect its weight sensors. Use a different scale with a higher weight range.

**Note:** If you still need help, please contact **Customer Support** (page 22).





## Federal Communication Commission Interference Statement – Part 15

This device complies with Part 15 of the FCC Rules. Operation is subject to the following two conditions:

1. This device may not cause harmful interference, and
2. This device must accept any interference received, including interference that may cause undesired operation.

NOTE: This equipment has been tested and found to comply with the limits for a Class B digital device, pursuant to Part 15 of the FCC Rules. These limits are designed to provide reasonable protection against harmful interference in a residential installation. This equipment generates, uses and can radiate radio frequency energy and, if not installed and used in accordance with the instructions, may cause harmful interference to radio communications. However, there is no guarantee that interference will not occur in a particular installation. If this equipment does cause harmful interference to radio or television reception, which can be determined by turning the equipment off and on, the user is encouraged to try to correct the interference by one of the following measures:

- Reorient or relocate the receiving antenna.
- Connect the equipment into an outlet on a circuit different from that to which the receiver is connected.
- Increase the separation between the equipment and receiver.
- Consult the dealer or an experienced radio/TV technician for help.

**FCC Caution:** Any changes or modifications not expressly approved by the party responsible for compliance could void the user's authority to operate this equipment.

## FCC Radiation Exposure Statement

This equipment complies with FCC radiation exposure limits set forth for an uncontrolled environment. End users must follow the specific operating instructions for satisfying RF exposure compliance. To maintain compliance with FCC RF exposure compliance requirements, please follow operation instructions as documented in this manual. This transmitter must not be co-located or operating in conjunction with any other antenna or transmitter. The availability of some specific channels and/or operational frequency bands are country dependent and are firmware programmed at the factory to match the intended destination. The firmware setting is not accessible by the end user.

## FCC SDOC SUPPLIER'S DECLARATION OF CONFORMITY

Etekcitey Corporation hereby declares that this equipment is in compliance with the FCC rules. The declaration of conformity may be consulted in the support section of our website, accessible from [www.etekcity.com](http://www.etekcity.com)



## Warranty Information

<b>Product</b>	Smart Nutrition Scale
<b>Model</b>	ESN00 Series

### Etekcitey Limited Product Warranty

Register your products at <https://warranty.etekcity.com/warranty> to stay up to date with important product information such as product updates, limited warranties, usage and maintenance recommendations, and notifications concerning safety warnings or product recalls. Registration is not required to claim your limited warranty.

### Two (2) Year Limited Consumer Product Warranty

Etekcitey Corporation ("Etekcitey") warrants that the product shall be free from defects in material and workmanship for a period of **2 years from the date of original purchase** ("Limited Warranty Period"), provided the product was used in accordance with its use and care instructions (e.g. in the intended environment and under normal circumstances).

### Your Limited Warranty Benefits

During the Limited Warranty Period and subject to this limited Warranty Policy, Etekcitey will, in its sole and exclusive discretion, either (i) refund the purchase price if the purchase was made directly from the online Etekcitey store, (ii) repair any defects in material or workmanship, (iii) replace the product with another product of equal or greater value, or (iv) provide store credit in the amount of the purchase price.

## Who is Covered?

This limited warranty extends only to the original consumer purchaser of the product and is not transferable to any subsequent owner of the product, regardless of whether the product transferred ownership during the specified term of the limited warranty. The original consumer purchaser must provide verification of the defect or malfunction and proof of the date of purchase to claim the Limited Warranty Benefits.

## Be Aware of Unauthorized Dealers or Sellers.

This limited warranty does not extend to products purchased from unauthorized dealers or sellers. Etekcity's limited warranty only extends to products purchased from authorized dealers or sellers that are subject to Etekcity's quality controls and have agreed to follow its quality controls. Please be aware, products purchased from an unauthorized website or dealer may be counterfeit, used, defective, or may not be designed for use in your country. You can protect yourself and your products by making sure you only purchase from Etekcity or its authorized dealers.

If you have any questions about a specific seller, or if you think you may have purchased your product from an unauthorized seller, please contact our Customer Support via [support@etekcity.com](mailto:support@etekcity.com).

## What's Not Covered?

- Normal wear and tear, including parts that might wear out over time (e.g. batteries, filters, cleaning brush, essential oil pads, etc.).
- If the proof-of-purchase has been altered in any way or is made illegible.
- If the model number, serial number or production date code on the product has been altered, removed or made illegible.
- If the product has been modified from its original condition.
- If the product has not been used in accordance with directions and instructions in the user manual.
- Damages caused by connecting peripherals, additional equipment or accessories other than those recommended in the user manual.
- Damages or defects caused by accident, abuse, misuse, or improper or inadequate maintenance.
- Damages or defects caused by service or repair of the product performed by an unauthorized service provider or by anyone other than Etekcity.



- Damages or defects occurring during commercial use, rental use, or any use for which the product is not intended.
- If the unit has been damaged, including but not limited to damage by animals, lightning, abnormal voltage, fire, natural disaster, transportation, dishwasher, or water (unless the user manual expressly states that the product is dishwasher safe).
- Incidental and consequential damages.
- Damages or defects exceeding the cost of the product.

## Claiming Your Limited Warranty Service in 5 Simple Steps:

1. Make sure your product is within the specified limited warranty period.
2. Make sure you have a copy of the invoice and order ID or proof-of-purchase.
3. Make sure you have your product. **DO NOT** dispose of your product before contacting us.
4. Contact our Customer Support team via [support@etekcity.com](mailto:support@etekcity.com).
5. Once our Customer Support team has approved your request, please return the product with a copy of the invoice and order ID.

## Sole and Exclusive Remedy.

THE FOREGOING LIMITED WARRANTY CONSTITUTES ETEKCITY CORPORATION'S EXCLUSIVE LIABILITY, AND YOUR SOLE AND EXCLUSIVE REMEDY, FOR ANY BREACH OF ANY WARRANTY OR OTHER NONCONFORMITY OF THE PRODUCT COVERED BY THIS LIMITED PRODUCT WARRANTY STATEMENT. THIS LIMITED WARRANTY IS EXCLUSIVE, AND IN LIEU OF ALL OTHER WARRANTIES. NO EMPLOYEE OF ETEKCITY CORPORATION OR ANY OTHER PARTY IS AUTHORIZED TO MAKE ANY WARRANTY IN ADDITION TO THE LIMITED WARRANTY IN THIS LIMITED PRODUCT WARRANTY STATEMENT.

## Disclaimer of Limited Warranties.

TO THE FULLEST EXTENT PROVIDED BY APPLICABLE LAW, EXCEPT AS WARRANTED IN THIS LIMITED PRODUCT WARRANTY POLICY, ETEKCITY CORPORATION PROVIDES THE PRODUCTS YOU PURCHASE FROM ETEKCITY CORPORATION "AS IS" AND ETEKCITY CORPORATION HEREBY DISCLAIMS ALL WARRANTIES OF ANY KIND, WHETHER EXPRESS OR IMPLIED, STATUTORY, OR OTHERWISE, INCLUDING BUT NOT LIMITED TO ANY



WARRANTIES OF MERCHANTABILITY, NON-INFRINGEMENT, AND FITNESS FOR PARTICULAR PURPOSE.

### **Limitations of Liability**

TO THE FULLEST EXTENT PROVIDED BY APPLICABLE LAW, IN NO EVENT WILL ETEKCITY CORPORATION, ITS AFFILIATES, OR THEIR LICENSORS, SERVICE PROVIDERS, EMPLOYEES, AGENTS, OFFICERS, OR DIRECTORS BE LIABLE FOR:

- (a) DAMAGES OF ANY KIND ARISING OUT OF OR IN CONNECTION WITH PRODUCTS PURCHASED FROM ETEKCITY CORPORATION IN EXCESS OF THE PURCHASE PRICE PAID BY THE PURCHASER FOR SUCH PRODUCTS, OR
- (b) INDIRECT, SPECIAL, INCIDENTAL, CONSEQUENTIAL, OR PUNITIVE DAMAGES EVEN IF ETEKCITY CORPORATION OR ONE OF ITS SUPPLIERS HAS BEEN ADVISED OF THE POSSIBILITY OR LIKELIHOOD OF SUCH DAMAGES.

AND REGARDLESS OF WHETHER CAUSED BY TORT (INCLUDING NEGLIGENCE), BREACH OF CONTRACT, OR OTHERWISE. OUR LIABILITY SHALL UNDER NO CIRCUMSTANCES EXCEED THE ACTUAL AMOUNT PAID BY YOU FOR THE DEFECTIVE PRODUCT, NOR SHALL WE UNDER ANY CIRCUMSTANCES BE LIABLE FOR ANY CONSEQUENTIAL, INCIDENTAL, SPECIAL OR PUNITIVE DAMAGES OR LOSSES, WHETHER DIRECT OR INDIRECT.

EXCEPT AS COVERED BY THIS LIMITED PRODUCT WARRANTY STATEMENT, ETEKCITY CORPORATION SHALL NOT BE LIABLE FOR COSTS ASSOCIATED WITH THE REPLACEMENT OR REPAIR OF PRODUCTS PURCHASED FROM IT, INCLUDING, BUT NOT LIMITED TO, LABOR, INSTALLATION, OR OTHER COSTS INCURRED BY THE USER AND, IN PARTICULAR, ANY COSTS RELATING TO THE REMOVAL OR REPLACEMENT OF ANY PRODUCT.

### **OTHER RIGHTS YOU MAY HAVE**

SOME JURISDICTIONS DO NOT ALLOW FOR: (1) EXCLUSION OF IMPLIED WARRANTIES; (2) LIMITATION ON THE DURATION OF IMPLIED WARRANTIES; AND/OR (3) EXCLUSION OR LIMITATION OF INCIDENTAL OR CONSEQUENTIAL DAMAGES; SO THE DISCLAIMERS IN THIS POLICY MAY NOT APPLY TO YOU. IN THESE JURISDICTIONS YOU HAVE ONLY THE IMPLIED WARRANTIES THAT ARE EXPRESSLY REQUIRED TO BE PROVIDED IN ACCORDANCE WITH APPLICABLE

LAW. THE LIMITATIONS OF WARRANTIES, LIABILITY, AND REMEDIES APPLY TO THE MAXIMUM EXTENT PERMITTED BY LAW.

ALTHOUGH THIS LIMITED WARRANTY GIVES YOU SPECIFIC LEGAL RIGHTS, YOU MAY HAVE OTHER RIGHTS IN YOUR JURISDICTION. THIS STATEMENT OF LIMITED WARRANTY IS SUBJECT TO APPLICABLE LAWS THAT APPLY TO YOU AND THE PRODUCT. PLEASE REVIEW THE LAWS IN YOUR JURISDICTION TO UNDERSTAND YOUR RIGHTS FULLY.

### **CHANGES TO THIS POLICY**

We may change the availability of this limited warranty at our discretion, but any changes will not be retroactive.

This warranty is made by:

Etekcitey Corporation  
1775 Flight Way, Suite 150  
Tustin, CA 92782  
USA



## Customer Support

If you have any questions or concerns about your new product, please contact our helpful Customer Support Team.

### **Etekcitey Corporation**

1775 Flight Way, Suite 150  
Tustin, CA 92782  
USA

**Email:** support@etekcity.com

**Toll-Free:** 1-855-686-3835

### **Support Hours**

Mon–Fri, 9:00 am–5:00 pm PST/PDT

*\*Please have your order invoice and order ID ready before contacting Customer Support.*



## Attributions

Google, Android, and Google Play are trademarks of Google LLC.

App Store® is a trademark of Apple Inc.

iOS is a registered trademark of Cisco Systems, Inc. and/or its affiliates in the United States and certain other countries.

The Bluetooth® word mark and logos are registered trademarks owned by Bluetooth SIG, Inc. and any use of such marks by Etekcitey Corporation is under license. Other trademarks and trade names are those of their respective owners.



**Connect with us @Etekcitey**



**etekcity™**